



Advanced Fuel Cycle  
Programme

# Coated Particle Fuel – The context and Kernel Manufacture

Nick Barron

# Background

- Coated Particle Fuels (TRISO fuels) are a specific type of fuel used in High Temperature Gas cooled Reactors (HTGRs).
- Fuel is extremely robust enabling high operating temperatures which:
  - **Increases efficiency of electricity generation**
  - **Permits high outlet temperatures suited to co-generation (e.g. H<sub>2</sub> production)**
- Particle fuel technology is mature
  - **First used in Dragon Reactor in 1964**
- HTGRs selected by government as preferred technology for AMR demonstration

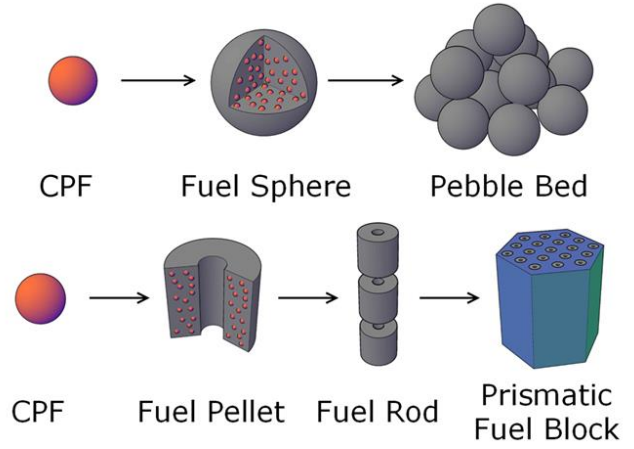

	1965-69	1970-74	1975-79	1980-84	1985-89	1990-94	1995-99	2000-04	2005-9	2010-14	2015-19	2020-21
Dragon Reactor, UK	█	█	█									
Peach Bottom, US		█	█									
Fort St. Vrain, US			█	█	█	█						
AVR, Germany		█	█	█	█	█						
THTR, Germany				█	█	█						
HTTR, Japan							█	█	█	█	█	█
HTR-10, China								█	█	█	█	█
HTR-PM, China												█

# International Interest

## UK

Potential demonstrator programme with fuel supply.

## Poland

Plans for new nuclear including interest in HTGR technology.

## Japan

HTTR first operated 1998-2011 and re-started in 2021.  
NFI 400kgU/yr fuel capability.  
Dormant since circa 2006.

## Canada

A number of HTGR vendors have started licence review with CNSC.

## USA

BWXT – Qualified “UCO” fuel, expanding 100kgU/yr capacity.

X-energy - \$80m USDoE support to develop the Xe-100 reactor and fuel capabilities.

## China

Operated HTGRs since 2000 (HTR-10) and 2020 (HTR-PM twin unit).

~ 3teU/yr fuel capability at Batou.



# Background

## Our work

- Develop UK capabilities and expertise through operation of “*engineering*” scale facilities to:
  - **ensure UK can be an intelligent customer to commercial fuel supply propositions; and/or**
  - **develop a UK fuel supply sufficient for a small demonstrator core (de-risk demo programme) and support domestic suppliers as they scale-up to build commercial supply.**
- Innovate to improve production methods
- Support UK supply chain to realise scale-up opportunities

## Our team

### Academia



### International



### Supply Chain



# Kernel Manufacture

## Our work

- Casting
  - Lab scale capabilities operation at NNL Preston and Lancaster University with research ongoing to optimise
  - Active commissioning of “*engineering scale*” capability
  - Alternative routes under development at Bangor
- Washing and Drying
  - Research ongoing to enhance efficiency of process
  - Active commissioning of “*engineering scale*” capability

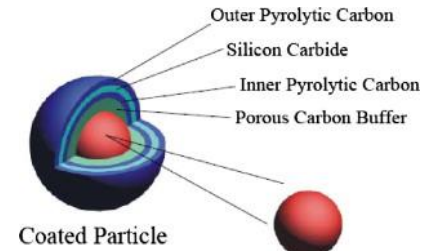
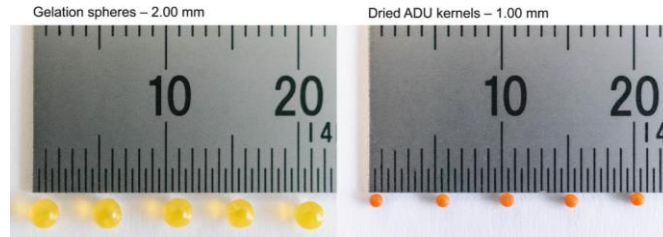

Fuel Kernel



# Kernel Manufacture

## Our work

- Calcining
  - **Optimisation ongoing to support operation of “engineering scale” capability**



- Reduction and Sintering
  - **Established technique in-place**
  - **Innovations also being supported – “Flash Sintering”**
- Quality Assurance

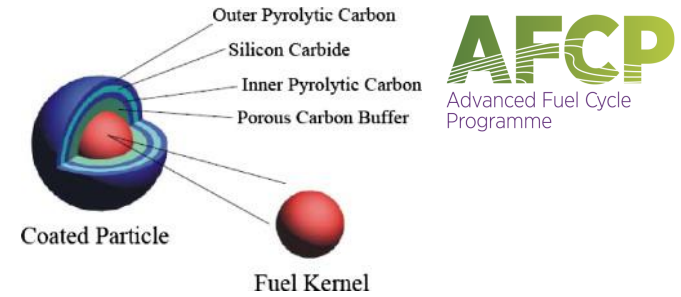



Advanced Fuel Cycle  
Programme

# Fluidised Bed Chemical Vapour Deposition in CPF manufacture

Mathieu Delmas

# Background

## Our work

- ATL, specialists in Chemical Vapour Deposition (CVD) for 40 years
- Involved in many materials research programmes for nuclear fusion & fission
- Building a new CVD reactor to coat uranic kernels to manufacture TRISO particles that will aid the enhancement of domestic understanding of this process

## Our team



HENRY ····  
ROYCE ····  
INSTITUTE

NATIONAL NUCLEAR  
LABORATORY



Find more about ATL at [www.cvd.co.uk](http://www.cvd.co.uk)



# Context

- TRISO particles, initially developed in the 1970s, are required for modern High Temperature Gas-Cooled Reactors (HTGRs)
- Beyond clean energy applications, they are also under consideration for other nuclear projects
  - **Space**
  - **Thermal nuclear propulsion**

# Highlights & Impact

- Pilot reactor nearing completion and FAT schedule confirmed
- First fluidised bed reactor built by ATL
- Various technical challenges solved (access to load/unload crucible, safety containment for any stray  $\text{UO}_2$  kernels, etc.).
- System able to apply 4 layers of 3 different coating types in one continuous batch
  - **Carbon and SiC**
- Fitted with many measurement tools to improve the process and its understanding
  - **Sampling probes, thermocouples, camera**

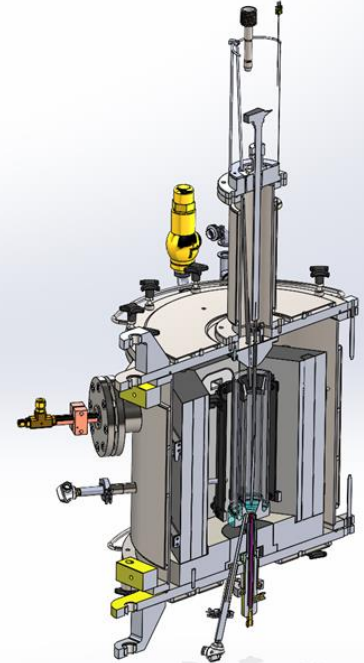
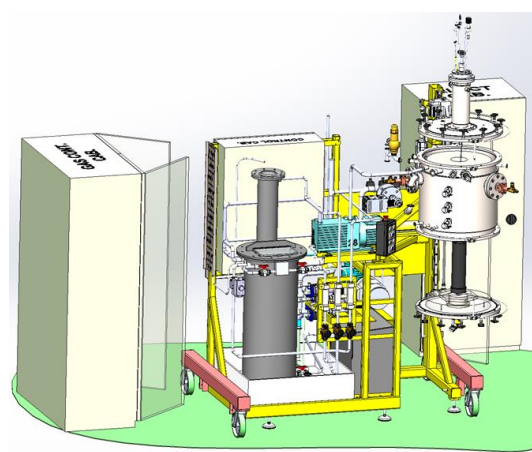



Advanced Fuel Cycle  
Programme

# Matrix Graphite and Pyrocarbon (PyC) Materials in Coated Particle Fuels

Nassia Tzelepi

# Background

## Our work

- Graphite matrix: the material in which the coated particles are embedded to produce spherical (pebbles) or cylindrical (compacts) fuel elements
- Pyrocarbon: The buffer, IPyC and OPyC layers used in coated particles to protect the fuel kernel and the SiC layer
- Key challenges:
  - **Limited available data of properties that affect fuel performance**
  - **Properties depend on manufacturing process**
  - **Micro-size of buffer and PyC samples**
- Two main objectives:
  - **Understand manufacturing parameters that affect fuel performance**
  - **Provide new data representative of the UK fuels**

## Our team



Matthew Jordan  
Samantha Wilkinson  
James McGladdery  
John Dinsdale-Potter  
Glen Copeland  
Michael Crelling  
Dave Goddard  
Dong Liu  
Alex Leide  
Eric Jiang  
Haiqi Huang



# Context

- *Graphite Matrix*: Moderator and main structural material
- *Pyrocarbon*: Protective layers for the fuel kernel and the SiC (pressure vessel)
  - **accommodating fission gas pressure and kernel swelling**
  - **providing chemical, thermal and mechanical stability barriers**
- Manufacturing parameters affect the properties of the as-manufactured material
- All properties change under irradiation
- Good understanding is required to manufacture high quality and reliable fuel pebbles/compacts
- *However, the UK has unparalleled experience and capability in nuclear graphite that can be extended to satisfy the requirements of AFCP*

Pebbles in the  
reactor



Source: Jiang, 2019

Examples of PyC  
failures

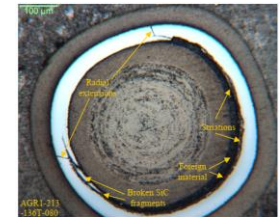
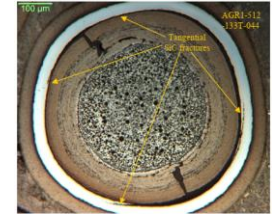

Source: Ploger, 2012

# Highlights & Impact

- Reports
  - **Graphite Matrix for TRISO Fuel: Review of Properties and Production Methods**
  - **Stress, Strain, and Slicing: Stress Redistribution caused by Hemisection of a Spherical Shell**
  - **Stresses and Strains in Spherical Shells Part 2: Analysis of Irradiation Creep**
  - **Review of TRISO-Relevant Pyrolytic Carbon Properties**
  - **Review of Measurement Techniques for Micro-sized Samples**
- Experimental: Development of measurement techniques for micro-sized PyC samples
  - **Sample preparation/machining**
  - **Mensuration**
  - **Elastic moduli (Resonant Ultrasound Spectroscopy (RUS))**
  - **Coefficient of Thermal Expansion (CTE)**

- Excellent collaboration with UoB
  - **Comparison of NNL theoretical analysis of stresses in manufactured and irradiated PyC layers with UoB residual stress measurement**

